

## Materials Processing Using an Atmospheric Pressure, RF-Generated Plasma Source

G.S. SELWYN, H.W. HERRMANN, J. PARK, AND I. HENINS

Plasma Physics Group, Los Alamos National Laboratory Los Alamos,  
NM 87544 USA

Received 22 March 2001, in final form 27 September 2001

### Abstract

Processing materials at atmospheric pressure provides clear advantages over traditional, vacuum-based plasma processing: in addition to reduction in the capital cost of equipment and the elimination of constraints imposed by vacuum-compatibility, high pressure and low temperature plasma processes offer unprecedented improvements for generation of active chemical species, high chemical selectivity, minimal ion densities resulting in low surface damage and surface treatment methods unattainable by other means. We describe several variations of this unique plasma source and some of its potential applications.

### 1 Introduction

Plasmas are generally classified as either thermal or non-thermal. Thermal plasmas are characterized by an equilibrium, or a near equality, between the three components of the plasma: electrons, ions and neutrals: i.e.,  $T_e \approx T_i \approx T_n$ . Thermal plasmas are always "hot"; temperatures of several thousand degrees are not unusual. Flames, certain arc discharges, plasma spraying and nuclear explosions are examples of thermal plasmas. While these plasmas have uses in waste treatment and sintering, they are not well suited for most materials processing applications because of their destructive nature.

Non-thermal plasmas are also frequently called, "non-equilibrium" plasmas because they are characterized by a large difference in the temperature of the electrons relative to the ions and neutrals. Since the electrons are extremely light, they move quickly and have almost no heat capacity. In these plasmas,  $T_e \gg T_i \approx T_n$ . Ionization is maintained by the impact of electrons (which may have temperatures ranging from 0.1 to more than 20 eV) with neutral species, producing additional electrons and ions. These plasmas are typically maintained by the passage of electrical current through a gas. The low temperatures typical of non-thermal plasmas makes them well suited for materials processing applications. However, unlike thermal plasmas, non-thermal plasmas generally have required vacuum, or low pressure operation.

Non-thermal plasmas have been extensively used for materials processing applications for the past 30 years [1]. Yet, these applications have generally been limited to select, high "value-added" uses, such as steps required for manufacture of semiconductor devices, magnetic media or deposition of energy-efficient films for architectural glass. In these applications, plasmas are used because they provide a rich source of chemically active species that react with a surface, or which react with each other to produce secondary, short-lived chemical precursors needed for thin film deposition. The success of plasma processing technology stems from its low temperature operation and the fact that no other method can provide the same nondestructive, materials

treatment capability. As such, plasmas are typically used for selective film etching, surface treatment to enhance wettability or to improve adhesion, and manufacture of thin films, including diamond-like carbon (DLC), and films having desired metallic, dielectric, or other composite properties.

But, what happens when traditional plasma treatment methods *overlap* conventional means of surface treatment, such as cleaning applications, or when vacuum-based processing presents obstacles, such as in sterilization or food treatment? In these cases, plasma processing often fails, either because the operation cost for the plasma-based method exceeds the cost for alternative method, or because the demands imposed by vacuum processing are excessive. This case is more the rule than the exception, as demonstrated in Figure 1.

Figure 1 shows two major constraints that arise for traditional, vacuum-based plasma processing: 1) the physical pressure limit required for operation of the plasma, and 2), the economic constraint imposed by this plasma treatment process. The first constraint arises from the need for vacuum operation in order to achieve plasma generation that is nondestructive to materials; the second constraint comes from the fact that the combined processing cost (i.e., the cost of consumables plus the amortized capital cost) must remain within a level acceptable to the customer. If both constraints cannot be simultaneously met, then the process is infeasible.

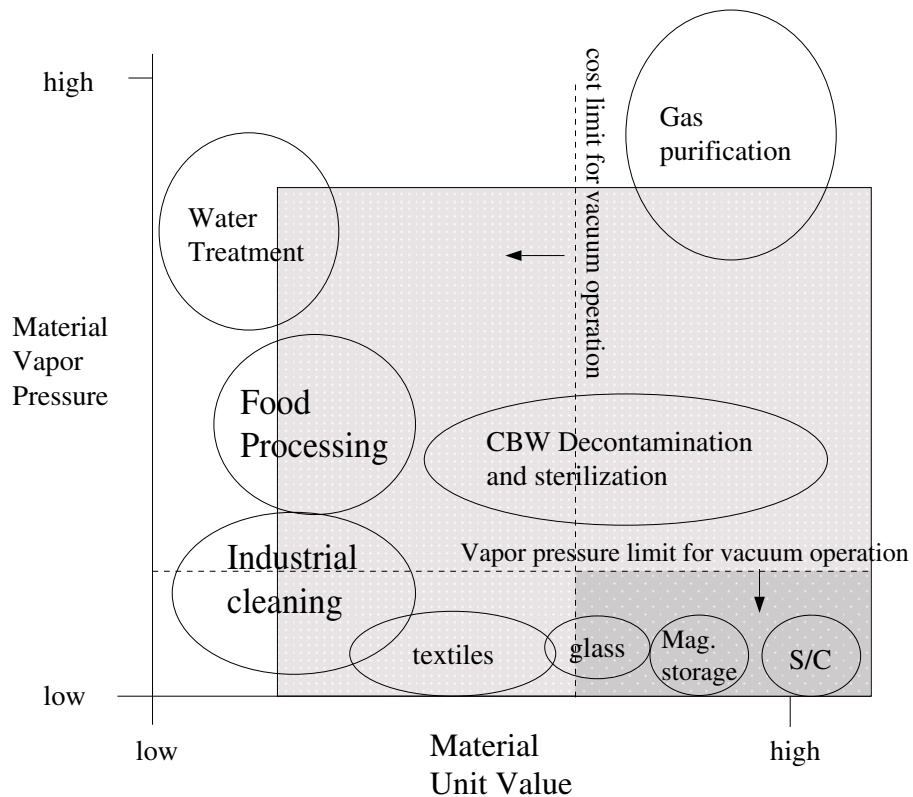

Fig. 1: Comparison of the process limits resulting from vapor pressure and economic constraints for both vacuum and atmospheric pressure plasma processing. The rectangular box in the lower right corner represents the domain for vacuum processing. The larger box represents the domain constraints for atmospheric pressure plasma processing. The larger box also contains much of the process domain represented for vacuum-based plasma processing.

Table 1 illustrates some of the applications associated with the materials processes shown in Figure 1 using non-thermal plasmas. Clearly, a broad range of treatment opportunities exists. For simplicity, only several examples are shown below.

Material/Substrate	Desired Component	Desired Product
Semiconductor substrates	Active neutral and ionic species generated by electron impact	Etching, thin film deposition, stripping, cleaning
Magnetic Storage Media	Sputtered atoms generated by ion bombardment of the target	Magnetic thin films, anti-corrosive coatings
Glass	Thin film chemical precursors, neutrals	Energy efficient coatings
Textiles	Ion bombardment, active neutrals	Increased wettability, wear properties
Industrial Cleaning	Oxygen atoms, ions	Oxidation and removal of organic films
Food Processing/Decontamination of CBW Agents/Medical Equipment	O, O <sub>2</sub> <sup>+</sup> , H, OH: chemical reactions initiated by plasma chemistry	Destruction or denature of pathogens, prions; chemical destruction of toxins
Water/Wastewater Treatment	O, O <sub>2</sub> <sup>+</sup> , O <sub>3</sub> , OH: chemical reactions initiated by plasma chemistry	Removal or destruction of water contaminants, pathogens, and reduction of biological oxygen demand (BOD)

Tab. 1: A brief compilation of various plasma/surface interactions using non-thermal plasmas and the active component of the plasma that contributes to the desired product or change.

The capital equipment cost and the high operation and maintenance costs required for vacuum-processing results in the relatively limited domain illustrated by the small, crosshatched region in the lower right hand corner of Figure 1. This figure shows that vacuum-compatible, high-value items, such as semiconductors, magnetic media, and specialty films used in architectural glass, are suitable opportunities for vacuum-based plasma processing. In contrast, the larger hatched region in Figure 1 illustrates the domain available for atmospheric pressure plasma processing. The greater domain available to this technology results from a higher vapor pressure limit and the lower materials processing cost associated from operation outside of vacuum at normal pressure. Even opportunities such as water and wastewater treatment pose potential opportunities for plasma processing, provided that the materials processing cost is acceptably low. Of course, developments that reduce the materials processing costs will change these results. Figure 1 is intended for qualitative comparison.

Several of these processes are illustrated diagrammatically in Figure 2. In the most general cases, the plasma is used as a chemical reactor, producing short-lived, active species that are formed by interaction of plasma electrons with the feedgas present in the plasma. This generality applies whether the plasma is produced in vacuum or at

atmospheric pressure.

Ions are always present in any plasma. Ions may enhance the surface reactivity contributed by active neutrals - such as in etching processes [2], or they may cause unwanted side effects - such as surface damage [3]. As such, design of materials processing methods requires a means to either increase or reduce the amount of ion interaction with the surface. In many cases, ions impart significant energy to a surface. This helps to drive a chemical reaction, or may even bring about a purely physical reaction process, such as sputtering of target material for metallic coatings. The use of combined, chemical + physical, reactions, are common in many plasma process steps. Note that a significant benefit of atmospheric pressure plasma processing results from the greater control available for selecting chemical or physical processes that result from ion interaction with the surface. This is because ion recombination and loss rates at high pressure are much faster than in vacuum.

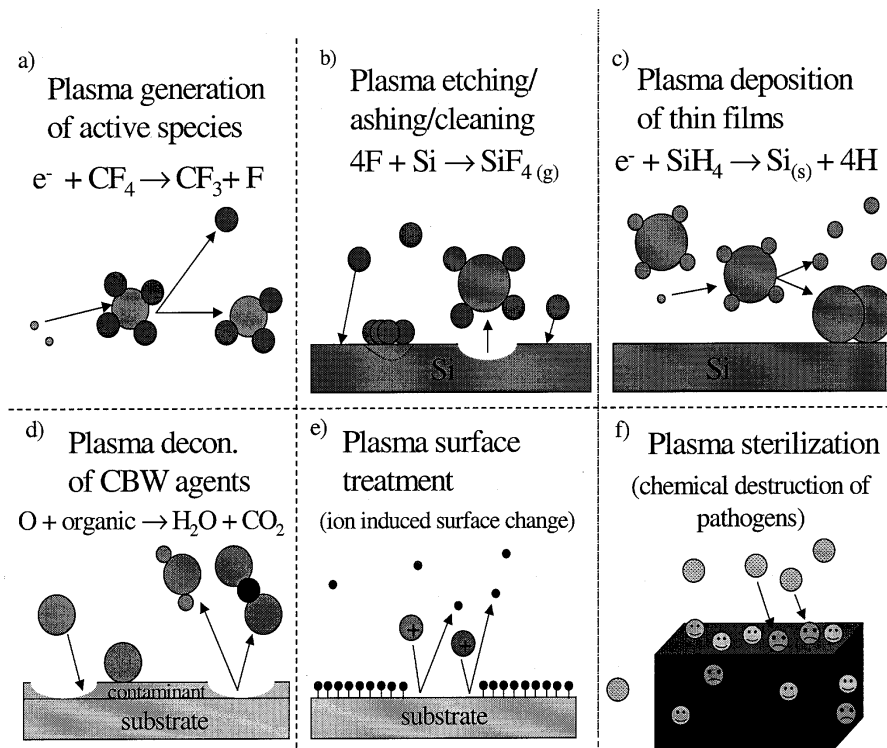

Fig. 2: An illustration of several of the fundamental processes used in plasma processing of materials. Some are purely chemical in nature; some involve physical contributions, such the impact of ions with the surface. Combinations of both chemical and physical processes are common.

## 2 Atmospheric Pressure Plasma Sources

Besides the aforementioned use of non-thermal plasmas in vacuum environments, several kinds of atmospheric pressure plasmas also are known [5]. Figure 3 illustrates some of the varieties of atmospheric pressure plasma sources. The so-called "dielectric barrier" discharge, Fig. 3a, utilizes a dielectric covering over one or both of the electrodes, of which one is typically low-frequency radio-frequency or ac driven, while

Table 2 summarizes the characteristics of thermal and nonthermal plasmas [4]

Plasma type	Pressure atm.	Electron/ion Density ( $\text{cm}^{-3}$ )	Electron Temperature K	Ion/Neutral Temperature K	Energy Source
Thermal	low pressure to many atm.	$10^{12}$ - $10^{19}$	5.000-500.000 (0.5-50 eV)	5.000-30.000	electrical nuclear combustion
Non-Thermal	typically low pressure	$10^8$ - $10^{13}$	1.000-50000 (0.1-5 eV)	100-1.000	electrical ionizing radiation

Tab. 2: Comparison of properties of thermal and non-thermal plasmas.

the other is grounded. The purpose of the dielectric film is to restrict and rapidly terminate the arcs that form in the potential field between the two electrodes. The discharge consists of a multitude of rapidly forming and equally-rapidly terminated arcs that fill the volume between the electrodes. Materials processing may be done using the ozone generated (in the case of an air or oxygen feedgas), or even by passing the substrate material - assuming it is a dielectric - within the discharge region between the electrodes.

The corona discharge, shown in Figure 3b, is a non-arcing, nonuniform plasma that ignites the region of the high electric field generated by the sharp points of the electrodes. To prevent arcing, no grounded surface can be near these field emission points, so the discharge is, by nature, non-uniform: plasma density drops off rapidly with increasing distance from the electrode.

The DC plasma torch, shown in Figure 3c, is often confused with the atmospheric pressure plasma jet to be described next. Unlike the other plasma sources shown in this figure, the plasma torch is a thermal plasma characterized by a high ion temperature  $\approx$  electron temperature. This source makes use of its very high gas temperatures for materials processing applications, primarily for chemical waste destruction, plasma spraying, deposition of ceramic coatings, and sintering applications. In addition to the dc plasma torch, other designs also exist that use radio-frequency for operation and which have inductive coupling (not shown in Fig. 4).

The fourth source shown as Figure 3d, is the atmospheric pressure plasma jet (APPJ). It is similar to the plasma torch in some respects, but is a true non-thermal plasma, as demonstrated by the vast difference in ion and electron temperatures. The APPJ source produces a stable, homogeneous and uniform discharge at atmospheric pressure using 13.56 MHz radio frequency power and a predominate fraction of helium feedgas. Unlike the silent discharge, the APPJ operates without any dielectric electrode cover, yet is free of filaments, streamers and arcing. The gas temperature of the discharge is typically between 50 and 300 C, so thermal damage to materials is easily avoided.

Figure 4 shows a photograph of the APPJ in operation. As described in the next section, this so-called cylindrical version of the plasma jet is only one kind of APPJ source. Several different variations exist. These different versions provide added

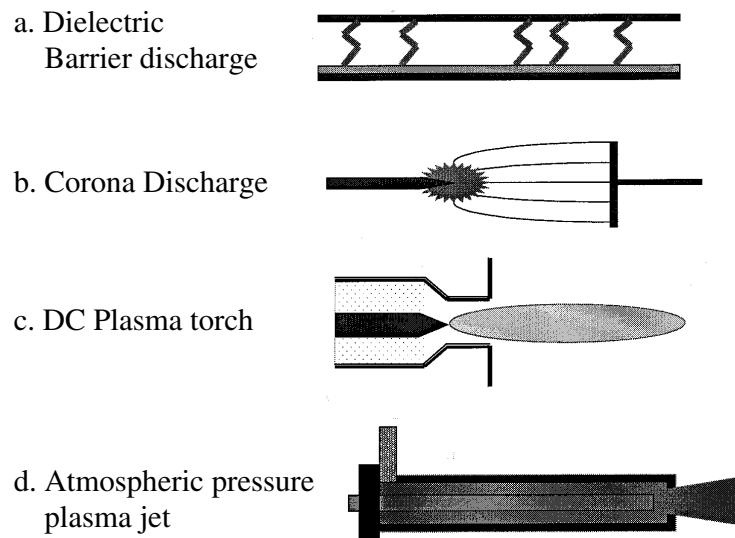

Fig. 3: Four different kinds of atmospheric pressure plasma sources.

benefit for certain applications. We have previously published several technical articles on the plasma physics and chemistry of this unique source [6, 7, 8, 9, 10, 11, 12].

In the design shown in Figures 3 & 4, helium feedgas ( $\approx 99\%$ ) mixed with a small amount of reactive gas (typically 1-3% oxygen) enters the annular volume formed between the rf-powered electrode (along the longitudinal axis of the source), and the outer, grounded metal tube. One novel aspect of this APPJ source is that the discharge is formed in this small volume - which typically has insufficient room for immersion of the workpiece or substrate, but the active chemical species formed by the plasma rapidly exit the source and impinge downstream on the workpiece [13]. In this way, the substrate is mostly exposed to active neutrals and radicals, rather than ions. The absence of ion chemistry in the downstream flow increases chemical selectivity and reduces surface damage. Of course, this design also uses large quantities of helium feed gas, because slow flow rates result in longer transit times, which favors the recombination or loss of the active, chemical species. Table 3 show typical process parameters for this source used under normal conditions.

### 3 Atmospheric Pressure Plasma Jet Sources and Applications

The cylindrical design shown in Figures 3d and 4 represent only one variation of the APPJ source technology. In some applications, especially where large area surface treatment is needed, it may be more desirable to use a similar design, but one in which flat, parallel, planar electrodes are used. A clear advantage of this approach is that the electrode size may be readily scaled up. Since the electrodes are securely held in place on either side, large areas (i.e.,  $1\text{ m}^2$  or more) may be achieved, keeping the gap between the electrodes precise. Figure 5 shows the design of a "flat jet" and a photograph of this source in operation. By placing the rf electrode between the two, outer, grounded electrodes, dual source operation is achieved, as well as providing a safer approach to handling the flat jet.

The flat jet also presents an interesting process opportunity for high pressure

RF frequency	13.56 MHz
RF power	250 W
Plasma power density	35 W/cm <sup>3</sup>
Discharge voltage	320 V <sub>rms</sub>
Electron density	~ 10 <sup>11</sup> cm <sup>-3</sup>
Electron temperature	~ 2-3 eV
He flow	92 slpm
O <sub>2</sub> flow	0.72 slpm
Gas velocity <sup>a,b</sup>	43 m/s
Effluent temperature <sup>b</sup>	150 °C
Ozone density <sup>b</sup>	~ 1x10 <sup>15</sup> cm <sup>-3</sup>
Atomic oxygen density <sup>b</sup>	~ 5x10 <sup>15</sup> cm <sup>-3</sup>
Metastable oxygen (O <sub>2</sub> <sup>1</sup> Δ <sub>g</sub> ) density <sup>b</sup>	~ 5x10 <sup>15</sup> cm <sup>-3</sup>

<sup>a</sup>using 8 mm diameter nozzle

<sup>b</sup>measured or estimated at nozzle exit

Tab. 3: Typical process parameters for the cylindrical APPJ source.

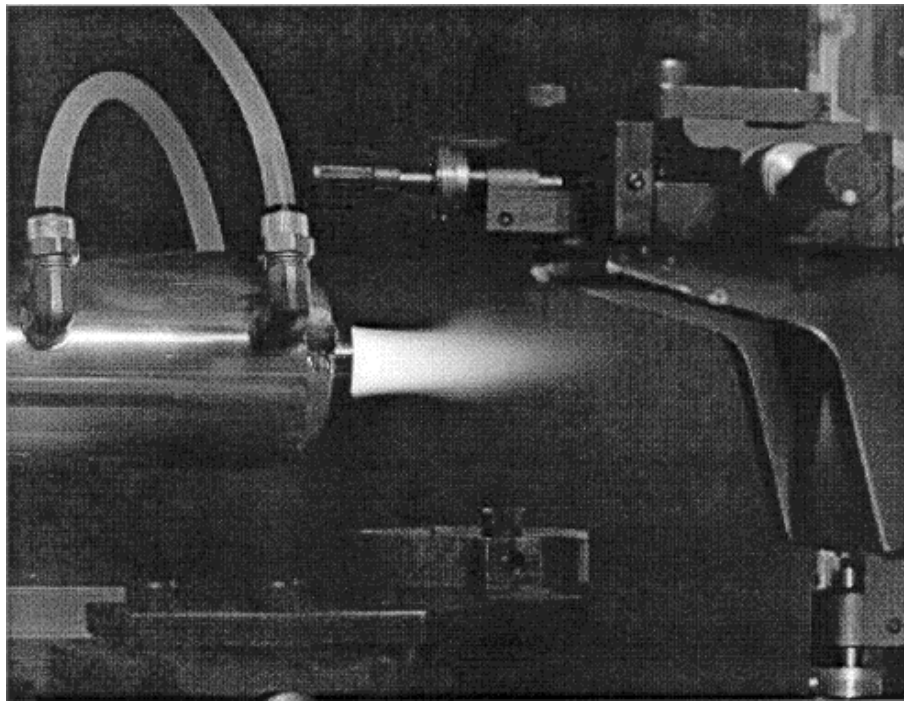

Fig. 4: Operation of a cylindrical version of the atmospheric pressure plasma jet. Note the effluent stream of reactive chemical species that exits from the end of the APPJ source.

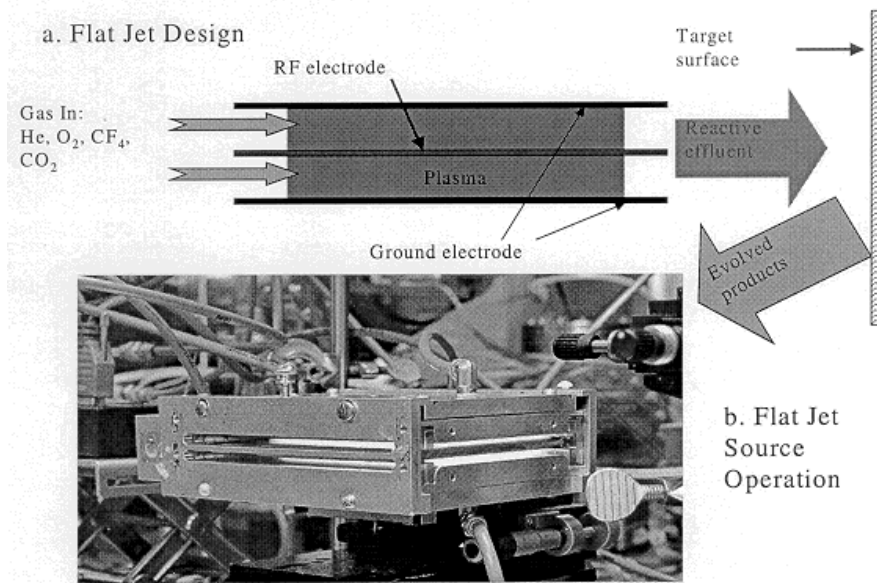

Fig. 5: Schematic drawing (a) of the flat jet and a photograph of the same in operation (b).

plasma processing. It may be used in either of two modes: 1) downstream operation, as shown in Figure 5a, or 2) for in-situ treatment of materials, accomplished by immersing the material on, or between, the rf-driven and grounded electrodes. Silicon wafers are ideally suited for the latter application because of their thin dimensions, as well as other materials, such as textiles. Even water or wastewater may be flowed along the surface of an electrode in order to expose it to the plasma. With the exception of wafer treatment, these opportunities would clearly be infeasible for vacuum-based plasma processing - not only because of the difficulty of feeding these materials into a vacuum chamber, but also because of the vapor pressure of the workpiece.

Figure 6 shows various means by which the APPJ source has been employed. All have similar properties and characteristics: i.e., use of helium to maintain a non-thermal plasma, low temperature processing, and high flux of reactive species impinging upon the substrate.

#### 4 Comparison of the APPJ Technology to Other Plasma Sources

All plasma processes have their relative advantages and disadvantages. For example, the highly collisional nature of the APPJ discharge makes it unlikely that this plasma may be used for directional etching of silicon, whereas a vacuum-based plasma serves this purpose well. Collisions are also responsible for the rapid removal of ions in the effluent stream exiting the source of the APPJ, so that this same phenomenon acts to reduce damage in photoresist ashing processes.

Still, a problem that APPJ applications must face is the high use rate of He feed gas. Helium is used to stabilize the discharge, and for electrode cooling, by virtue of its high thermal conductivity. For this reason, most commercial applications employing APPJ technology will have to use equipment for recirculation and repurification of the feed gas. While this slightly increases the capital cost of the equipment, the operating

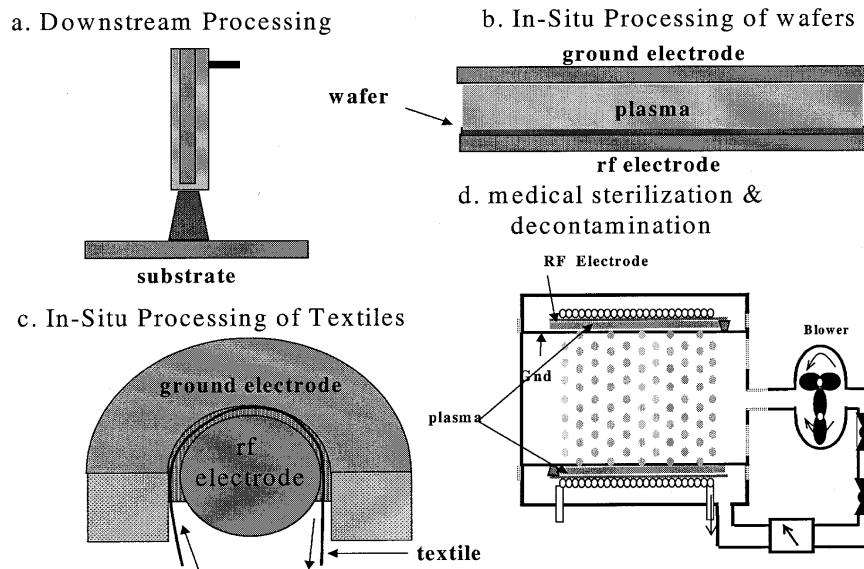

Fig. 6: Variations in use of the APPJ technology and different source designs.

costs are greatly reduced. Complete systems for filtering He are commercially available. A helium reprocessing system is indicated in Figure 6d. Not only do these systems reduce the cost-of-ownership (COO) by reusing the helium carrier gas, but they also increase the domain of potential applications by moving the left axis of the large box in Figure 1 further to the left, enabling applications that have lower material unit value. We have demonstrated this helium recovery system in a system designed for decontamination of materials having chemical or biological warfare agents, another potential use for the plasma jet [14].

While there is still more to go in development in a wide variety of these plasma sources and applications, we believe, nonetheless, that atmospheric pressure plasma is a promising technology, not only for the future, but also for today's processes and applications.

## References

- [1] C.J. Mogab, *VLSI Technology* (ed. S.M. Sze), McGraw Hill (New York), pp 303-346, (1983)
- [2] J.W. Coburn, *Plasma Chem. Plasma Proc.*, **2**, 1 (1982)
- [3] K.F. You, M.C. Chang and C.Y. Wu, *IEEE Trans. Elect. Dev.*, **45**, 239 (1998)
- [4] M.A. Liebermann and A. J. Lichtenberg, *Principles of Plasma Discharges and Materials Processing*, Wiley-Interscience, pp 6-10, (1994)
- [5] A. Schuetze, J.Y. Jeong, S.E. Babayan, J. Park, G.S. Selwyn and R.F. Hicks, *IEEE Trans. Plasma Sci.*, **26** 1685 (1998)
- [6] S.E. Babayan, J.Y. Joeng, V.J. Tu, J. Park, G.S. Selwyn and R.F. Hicks, *Plasma Sources Sci. Technol.*, **7**, 286 (1998)
- [7] J.Y. Jeong, S.E. Babayan, V.J. Tu, J. Park, I. Henins, R.F. Hicks and G.S. Selwyn, *Plasma Sources Sci. Technol.*, **7**, 282 (1998)
- [8] J.Y. Jeong, J. Park, I. Henins, S.E. Babayan, V.J. Tu, G.S. Selwyn, G. Ding and R.F. Hicks, *J. Phys. Chem.*, **2000**, 8027 (2000)

- [9] J. Park, I. Henins, H.W. Herrmann and G.S. Selwyn *J. Appl. Phys.*, **89**, 20 (2001)
- [10] V.J. Tu, J.Y. Jeong, A. Schutze, S.E. Babayan, G. Ding G.S. Selwyn and R.F. Hicks, *J. Vac. Sci. Technol. A*, **18**, 2799 (2000)
- [11] J. Park, I. Henins, H.W. Herrmann and G.S. Selwyn *J. Appl. Phys.*, **89**, 15 (2001)
- [12] J. Park, I. Henins, H.W. Herrmann and G.S. Selwyn, J.Y. Jeong, R.F. Hicks, D. Shim and C.S. Chang, *Appl. Phys. Lett.*, **76**, 288 (2000)
- [13] US Patent No. 5.961.772 issued Oct. 5, 1999
- [14] H.W. Herrmann, I. Henins, J. Park and G.S. Selwyn, *Physics of Plasmas*, **6**, 2284 (1999)